

## INSTALLATION INSTRUCTIONS WALL MOUNT/LARGE SIGN – MOUNT D

1. Mount hanger strip. Bottom of strip is to be 1-3/8" from the top of sign. Check to make sure the strip has been installed level. The hanger strip has holes 8" on center and should be mounted on studs, if possible. If not, proper anchors must be used.
2. Hang sign on hanger strip.
3. Remove end cap or side frame from either side of the sign. Locking end caps will require a lock pin or #6 Phillips screwdriver tip to remove the end cap, depending on thin or standard sign. Slide out bottom copy insert to expose the rail locking screw holes and install locking screws.
4. Replace insert and end cap or side frame.

All screws and anchors required for mounting this sign are included in the hardware package.

Note: Use the standard D-Mount #6x1-5/8" trim screws and anchors for the hanger strip and the rail locking screws.

If there are any questions, please contact our Technical Support Department at 800.777.4310.

### Typical Application:

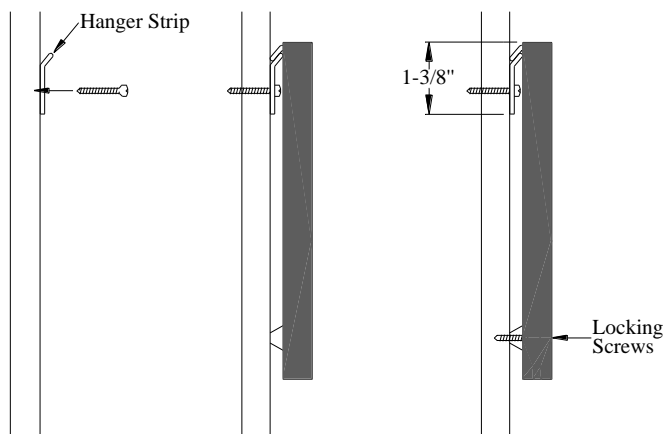

**IMPORTANT:** Prior to installation, remove all contents from box and inspect each sign for damage. Box should contain signs, hardware, and mounting instructions for each style of mount used. Surface of the sign must be handled with care. Clean with water and mild detergent.

**Customer is responsible for suitability of each mounting option. Testing is recommended prior to each use.**

Rev. 08/31/10